

WALL LIGHT

LIGHTING SERIES



CE RoHS

5 Years Warranty

Features

- Main structural components for lamp body is ADC12 Die-cast aluminum, with advantages of Shock Resistance, Corrosion Resistance.
- High temperature resistance silicone seals, no atomization.
- Electrostatic spray processing for Structural components.
- Corrosion Resistance, fungus-proof testing for 1000hrs.
- Imported PC material for optical lens.
- IP65 Waterproof
- Application for Square, Billboard, Parking Lot, Garden, Building, Factory, Warehouse, Stadium, Gas Station, etc.

Dimension

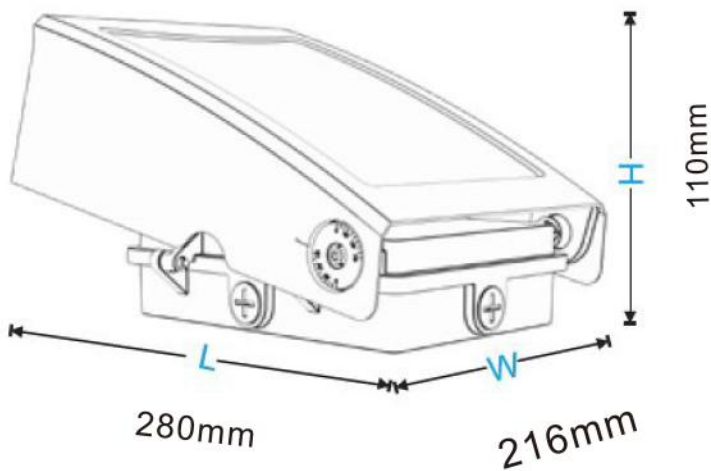

Dimension

Parameter	Rating
Heat Sink Temp	65°C
Operating Temp	-20 ~+ 65°C
Storage Temp	-40 ~+ 80°C
Equilibrium Temp	25°C

Aging



Ordering information

Model	Power	Size	Lumen	CCT	Voltage	Power Factor	CRI	Net Weight
ILS-WPK2-40W	40W	205X165X98MM	5200LM	2700/3000/4000/5000/>6000K	AC100-277V	>0.95	≥83	2.2kg
ILS-WPK2-60W	60W	280X216X110MM	7800LM	2700/3000/4000/5000/>6000K	AC100-277V	>0.95	≥83	2.9kg
ILS-WPK2-100W	100W	330X267X124MM	13000LM	2700/3000/4000/5000/>6000K	AC100-277V	>0.95	≥83	3.5kg
ILS-WPK2-120W	120W	330X267X124MM	15600LM	2700/3000/4000/5000/>6000K	AC100-277V	>0.95	≥83	4.1kg



Product Packing Specification

Packing Details	
Box Size	340X270X160MM
Pack Quantity	1pcs/ctn
Gross Weight	2.9Kg/ctn

