

COMPOUND LIGHTING POLE SERIES

8.0M Column Lighting Pole Wall-Mounted, ILS-N-CL002B-WL, 60W LED

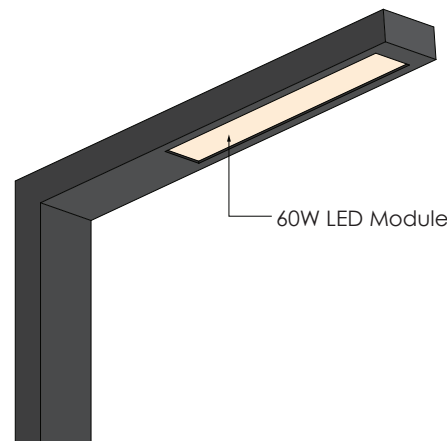

60W LED Module

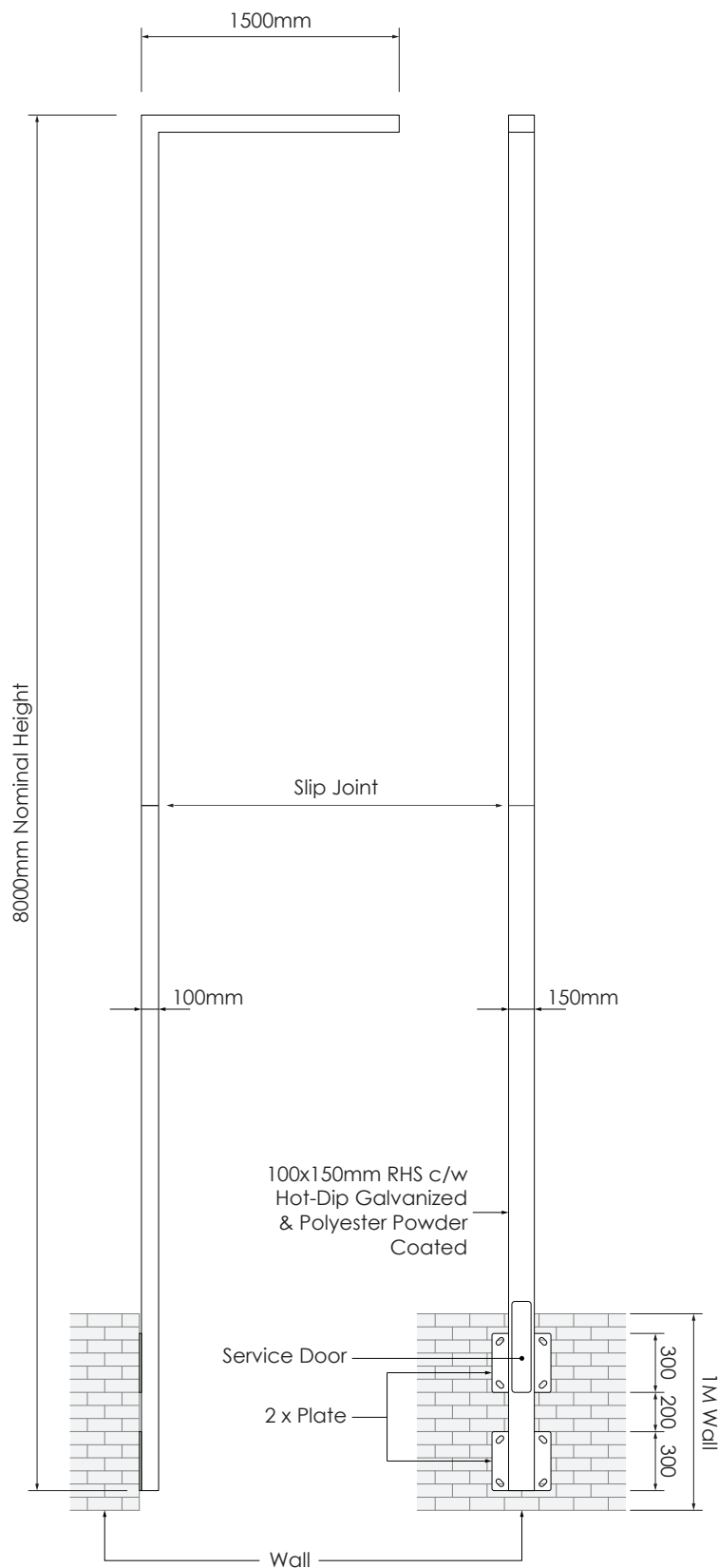

Model	: ILS-N-CL001
Power	: 60W
Input Voltage	: 110-220Vac, 50/60Hz
Lamp Type	: CREE LED Module
Light Efficacy	: 170lm/w
Color Temperature	: 3000K - 6500K
Color Rendering Index	: Ra>80
IP Rating	: IP65

Pole Specifications :-

1) Design Conditions

1.1 Basic Wind Speed	: 35 m/s
----------------------	----------

2) Standards

2.1 Pole Design	: BS 5649 CP3
2.2 Material	: BS 4360 / BS 1387
2.3 Welding (Electric Arc Welding)	: BS 5135
2.4 Galvanizing	: BS 729
2.5 Powder Coating	: BS 6497
2.6 ISO Manufacture	: ISO : 9001-2000
2.7 SIRIM Galvanized Test	: 60-65 Micron
2.8 Tensile test	

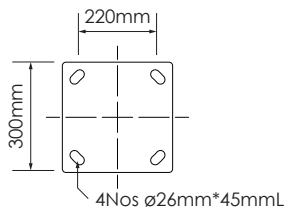

FLANGE PLATE (12mm Thickness)

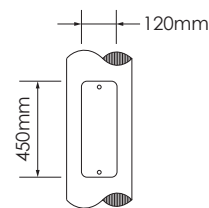

SERVICE DOOR

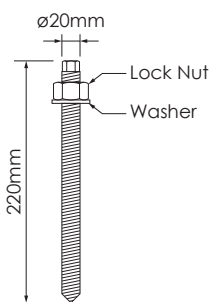

M20 CHEMICAL ANCHOR BOLT

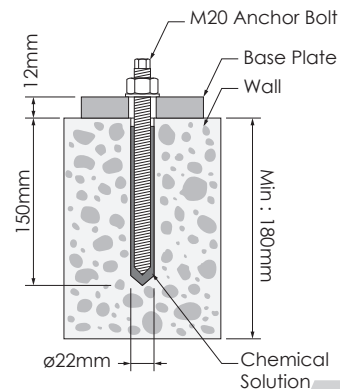

APPLICATION DIAGRAM



+6016-6815 840 | Jason Chiew



ils_jason@hotmail.com